

ARITERM ENERGY

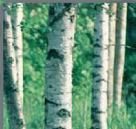

INSTALLATION and OPERATING INSTRUCTIONS

- Ariterm BeQuem 40

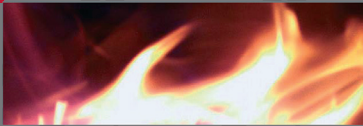

■ TABLE OF CONTENTS

General information and contents of delivery	2
Transport, storage and unpacking	2
Technical data	3
Common spare parts	3
Function description and safety	4
Burner compatibility with boiler	5
Installing the burner	5
Installing adapter flange and slide mount	6
Wiring diagram	7
Control panel	8
Burner operation	8
Burner start, burner function	9
Adjustment of combustion	10
Menu structure	11-14
Alarms and troubleshooting	15-16
Service and maintenance	17-18
Wood pellets as fuel	19
Declaration of conformity	19
Installation report	20
Notes	21-23

■ Contents of delivery

- Ariterm Bequem 40 pellet burner (incl. sensors and power supply cable)
- burner flange+packing
- quick release handles
- sliding guide
- fall pipe 1m
- installation and maintenance

■ GENERAL INFORMATION

■ General

The new BeQuem 40 pellet burner is an easy to use, reliable and fireproof burner. The advanced automatic function is clear and easy to use. The automatic function detects different fault modes and gives the reason for the alarm on the display. After a power cut, the burner automatically resumes operation. The required boiler water temperature is set via the user interface and the burner's operation is automatically controlled. The burner's operating status can be followed via the user interface.

■ Important information

Keep the manual and read it carefully before use. It pays off to carry out the services according to the recommendations so that the combustion process is as efficient as possible.

A company with professional knowledge should perform the installation of the burner. Overheat protection should be installed in the burner's power supply to cut the power to the burner if the boiler water temperature exceeds the maximum permitted. The installer should be authorised for electrical work.

NOTE! The overheat protection is not delivered with the burner.

The burner's output is calculated from the supplied output. The average properties of the wood pellets must agree with the fuel specification and the conditions, such as the draught, should be according to the recommendations.

NOTE! The burner's protective cover may only be removed if the burner's main power is disconnected. Follow the advice in the manual and carry out service on the burner according to the recommendations.

■ Transport, storage and unpacking

The factory has transport insurance that covers transport damage that may occur during transport from the factory to the first intermediate storage site. It is important for the recipient of the burner to check the burner's condition before receipt is confirmed. In the case of damage, the vendor must immediately be contacted.

Storage

The burner may be stored outdoors for a short period, protected from the rain. It is however best to store the burner indoors.

Disposal of packaging

The cardboard box can be recycled.

TECHNICAL DATA

COMMON SPARE PARTS

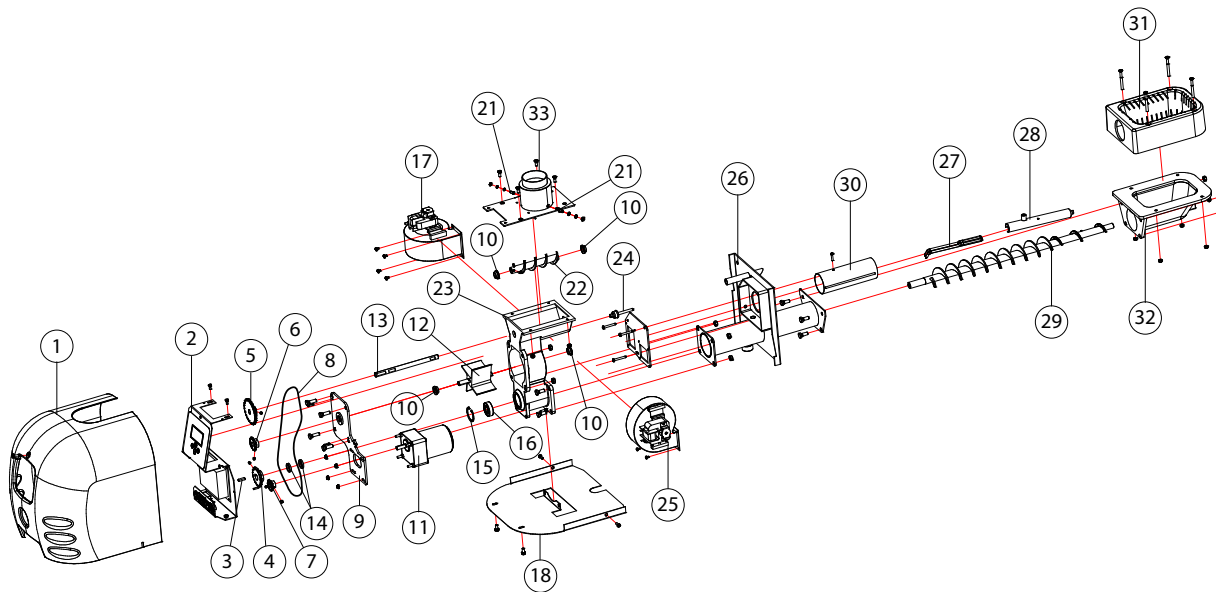

TECHNICAL DATA

Capacity	Output with pellets Specific output Combustion efficiency Firing element output Basic power requirement Maximum power requirement	12 - 40 kW 40 kW 95,9 % 450 W 60 W 530 W
Measurement details	External length External width Internal length Weight Minimum width for installation opening height Combustion space above burner head	370 mm 350 mm 420 mm 40 kg 230 mm 225 mm 350 mm
Electrical data	Electrical supply Supply cable Fuse size Connection output Standby mode Maximum motor size for external auger	230 V 50 Hz 1~ 3x1,5 1x10 A 730 W 3 W 230 W (1A)
Other	Noise level Emission class Fuel	58 dB 4 Pellets $\varnothing = 8$ mm (recommendation)

Nr	Product nr	Product name
1	5076	Burner cover BQ50-202
2	5993	Control panel BQ40
3	5346	Chain wheel Z=12
4	5875	Chain wheel Z=17
5	5831	Chain wheel Z=24
6	5081	Chain wheel Z=18
7	5840	Oil bronze bearing 12/18x12-24x3
8	5425	Oil bronze bearing 12/18x8-24x3
9	5486	Rotary block feeder
10	5360+5361	Lever sensor
11	5935	Feeding auger
12	5328	Burner cup
13	5963	Primary air ring
14	5415	Ignition element
15	5308	Primary fan DSA326-128
16	5939	Secondary fan DSA326-115
17	5416	Ball bearing 6023.2RSR
18	5307	Burner motor 40 W
19	5886	Chain 77 loops
20	5359	Flame sensor

FUNCTION DESCRIPTION AND SAFETY

The BeQuem 40 pellet burner is an easy to use burner. The power is connected to the burner and the burner is set up for operation from a menu. The burner checks its status automatically and when necessary carries out a cold start with the help of the firing element. When necessary the burner can also be lit manually (light the pellets and choose On mode for the burner from the menu).

The burner warms up the boiler water to the required temperature with the help of the boiler temperature sensor and then goes into maintenance mode. When the boiler water temperature has fallen as much as the hysteresis (the temperature difference), the burner ignites with the help of the embers in the burner head to save energy. Alternatively, the burner can be set up so the ignition is always carried out using the firing element, which means that the burner does not hold any embers in the burner bowl (for example, when operating with accumulator tank).

The burner controls the store auger automatically. When the pellet surface in the upper connection falls below the level sensors that measure the pellet surface, the store auger starts and feeds pellets to the burner.

The burner head is supplied with an exact mixture of pellets and air that achieves complete combustion, which is cost effective and environmentally friendly.

Safety

For safety reasons, the pellet heating unit and the fuel store are separate from each other. This eliminates the risk of accidents. Operational disruptions or damage caused by incorrect use are restricted to the burner. The fuel store should be divided off as a separate fire-rated space. On each refilling, a small amount of pellets (150 g) is supplied from the fuel store via the external feeding device to the burner's upper connection. So that a pellet quantity of exactly the same size is dispensed to the burner head, dosing is done with the help of the external feeder auger via the rotary lock feeder and the auger burner to the burner head.

The auger burner feeds pellets three times faster than they come to the auger. This creates a protection zone with only a few pellets between the burner head and the upper connection. Even if the equipment should be affected by a power cut, neglected service or if a part fails, this protection zone remains intact.

The auger burner has overpressure during operation. This function should minimise the risk that the burner is damaged, for example due to poor draught.

The burner's automatic function stops the burner in the event of a fault, and a red signal lamp is lit. The display also shows an alarm text giving the cause of the fault. A description of the alarm can be found under the heading "Fault finding".

The burner's combustion air fan is equipped with a rotation sensor (tachometer) that monitors burner function.

Air is fed into the flame sensor pipe, which increases the lifetime of the sensor and keeps it clean.

Burner function

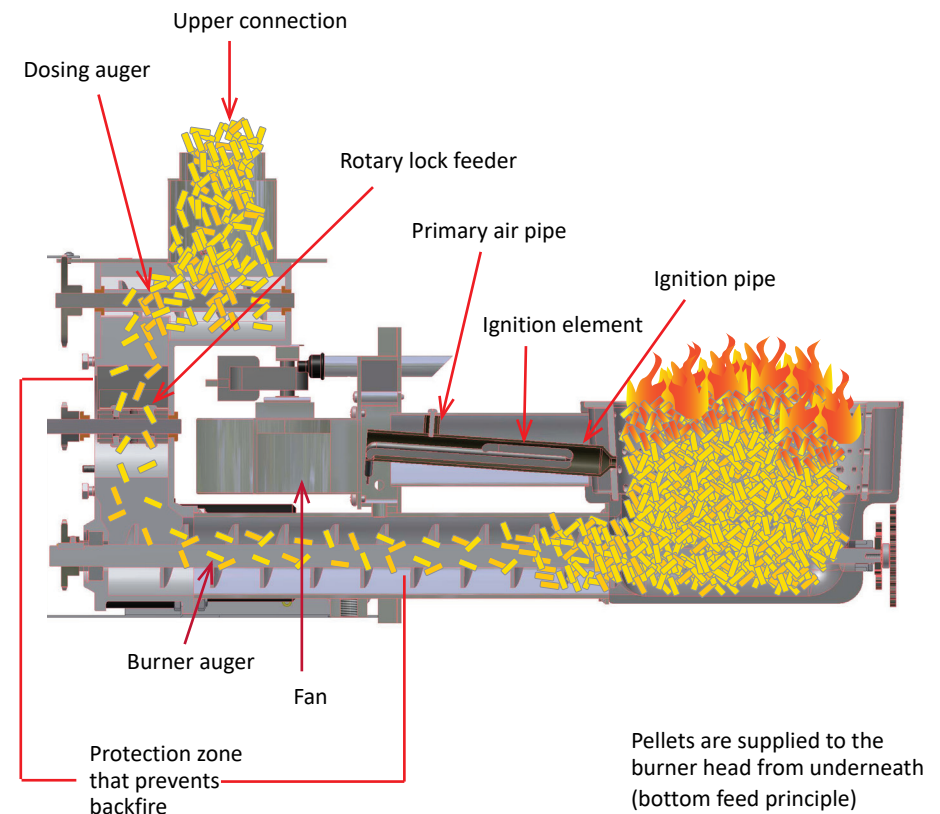

■ BURNER COMPATIBILITY WITH BOILER

The pellet burner is suitable for installation in boilers that fulfil certain requirements in terms of hearth size and have sufficient vacuum and space for ash. In addition, the boiler room must have a sufficiently large opening for replacement air (see technical data).

■ Requirement for hearth size

Hearth depth: at least 350 mm measured from the installation hatch. Free height above the burner head: at least 250 mm, which ensures sufficient combustion space for the flame.

■ Space for ash

The boiler should have large enough space for ash beneath the burner head so that the interval for ash removal is sufficiently long and the functioning of the burner remains reliable. Ash removal should take place through a separate service hatch, so that the burner does not need to be removed when the process takes place.

■ Hearth vacuum

The hearth should have sufficient vacuum (natural draught), which makes possible efficient combustion of the pellets. As a guideline, ca. 10 Pascal in the combustion chamber.

■ Electrical installation

Supplied together with the burner are:

- the connection cable for the burner's power supply, 2 m
- the connection cable for the temperature sensors, 2 m
- the smoke gas sensor and extension cable, 2 m
- and the boiler sensor.

Only authorised electrical installers may carry out the electrical installation. The burner's power supply should be carried out according to the wiring diagram. Overheat protection (HVAC-code 5154361) should be installed in the burner's power supply in such a way that it cuts off the power to the burner if the boiler water temperature becomes too high. In addition, the use of a safety switch (burner switch) in the power supply is recommended. The boiler sensor should be installed in the same sensor well as the overheat protection sensor, if this is possible. The smoke gas sensor is installed in the flue connection.

NOTE! A company with professional knowledge should perform the installation of the burner. The installation should be carried out so that it fulfils at a minimum the requirements in standard SFS 3332.

■ INSTALLING THE BURNER

An adapter plate is delivered with the burner, and should be fixed to the boiler with a tight joint. The seal that accompanies the burner should be positioned between the burner flange and the burner. (Figures showing the installation can be found on the next page.)

■ Installation instructions

1. Fix the burner flange firmly and tightly to the boiler.
2. Install the burner rails and quick release handle.
3. Fix the burner to the boiler.
4. Install the overheat protection in the boiler and connect the burner's power supply via the protection.
5. Install the boiler sensor and the smoke gas sensor in their respective places.
6. Install the fall pipe between the burner and the storage auger.

■ Details that should be checked before commissioning

- that the heating system and boiler are filled with water, with a pressure of at least 0.5 bar
- that any smoke gas damper is open
- that the butterfly valve in the boiler's convection section is in place
- that the circulation pump is on
- that the heating system's taps are open
- that the opening for combustion air is open
- that the safety valve is connected to the boiler without problem and that the safety valve is in working order.

■ Checking burner function after installation (installer)

1. Carry out all electrical connections to the burner.
2. Check the burner sensor value on the burner display.
3. Check the smoke gas sensor value on the burner display.
4. Start the external auger from the main menu and wait until pellets begin to come through to the burner. Stop the external auger.
5. Set the burner to On mode. The burner begins a cold start (start 1K). The cold start continues for about 30 minutes.
6. When the burner has switched to high output, check the external auger's operating time. The pellet surface should be level with the burner's upper connection. Operating times can be altered from the Power Settings menu.
7. Set up the burner with the help of a smoke gas analyser.

■ INSTALLING THE ADAPTER FLANGE AND SLIDE MOUNT

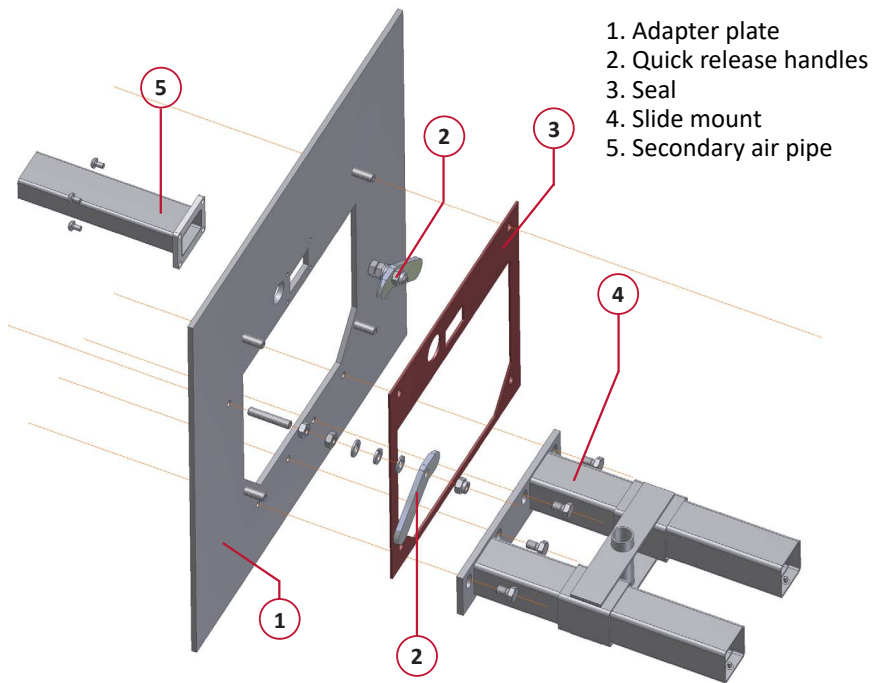

1. Adapter plate
2. Quick release handles
3. Seal
4. Slide mount
5. Secondary air pipe

Mount the quick-release handles, slide mount and secondary air pipe as shown in the photograph.

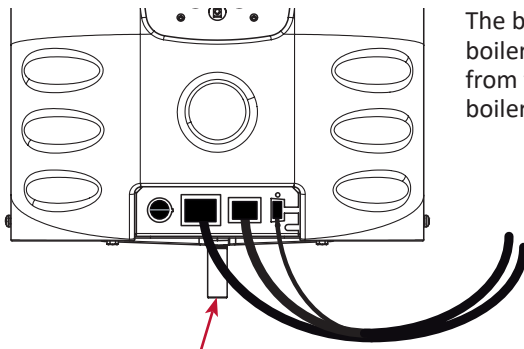

Slide mount fastening pin

The burner cables should be attached to the boiler so that the plugs must be removed from the burner before it is pulled out of the boiler.

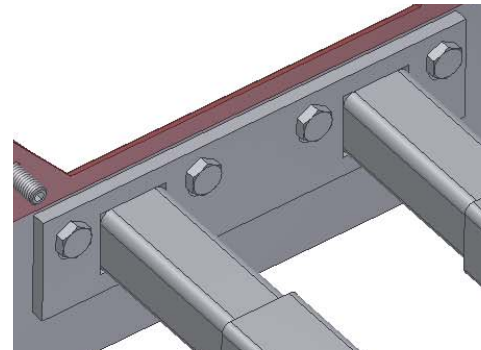

Install the slide mount according to the figure. The final attachment of the slide mount is done when the burner is attached to the adapter plate. The slide mount is lifted up against the slide mount fastening pin and the screws are tightened.

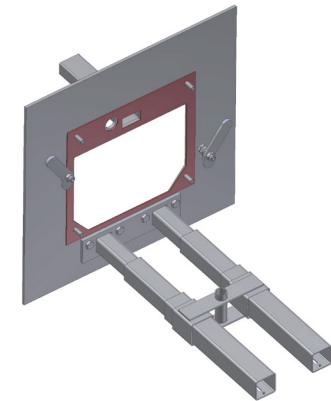

Installed slide mount and quick release.

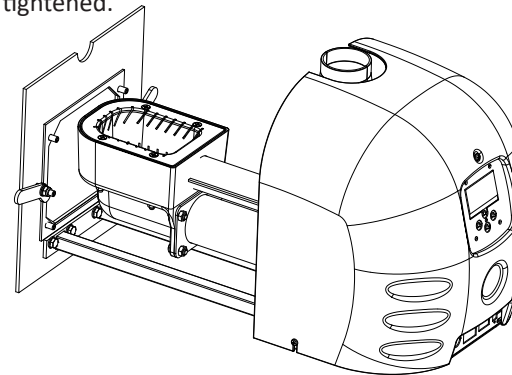

Mark out the points for the boiler's mounting pins, and drill holes at the marked points. The seal between the adapter plate and the boiler should be made with sealing tape or equivalent.

NOTE! Check that the burner is centered in relation to the dowel bolts when the burner is pulled out of or pushed into the boiler. The rails should also be greased so that the burner slides more easily. Finally, when the burner has been pushed into the boiler, set the burner's quick release.

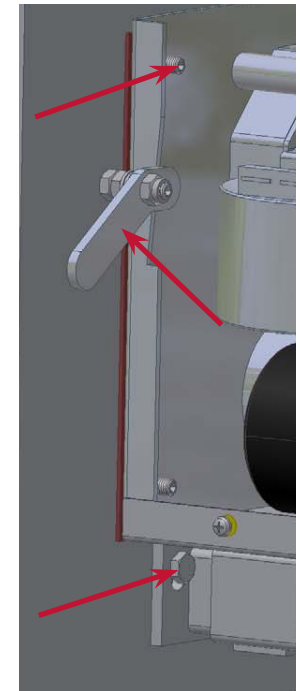

WIRING DIAGRAM

S1 ON/OFF -SWITCH, BURNER
 X21 SUPPLY VOLTAGE ADAPTER
 X22 EXTERNAL ALUGER. ADAPTER
 X23 SENSOR ADAPTER
 T1 OVERHEATING THERMOSTAT

INSTALLATION

Overheating thermostat must be installed that it cuts the voltage from burner when boiler water temperature rises over limit.

Install the sensor of overheating thermostat in some pocket on boiler sensor, if it is possible.

It is recommended to use safety switch (burner switch) in power supply.

ALARM RELAY

When alarm is activated, the burner will stop. For example you can connect pilot lamp or GSM alarm system to alarm relay and you get information that burner is stopped. Contact is potentially free.

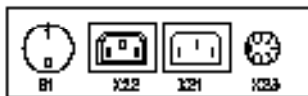

EXTERNAL CABLING

OVERHEATING THERMOSTAT

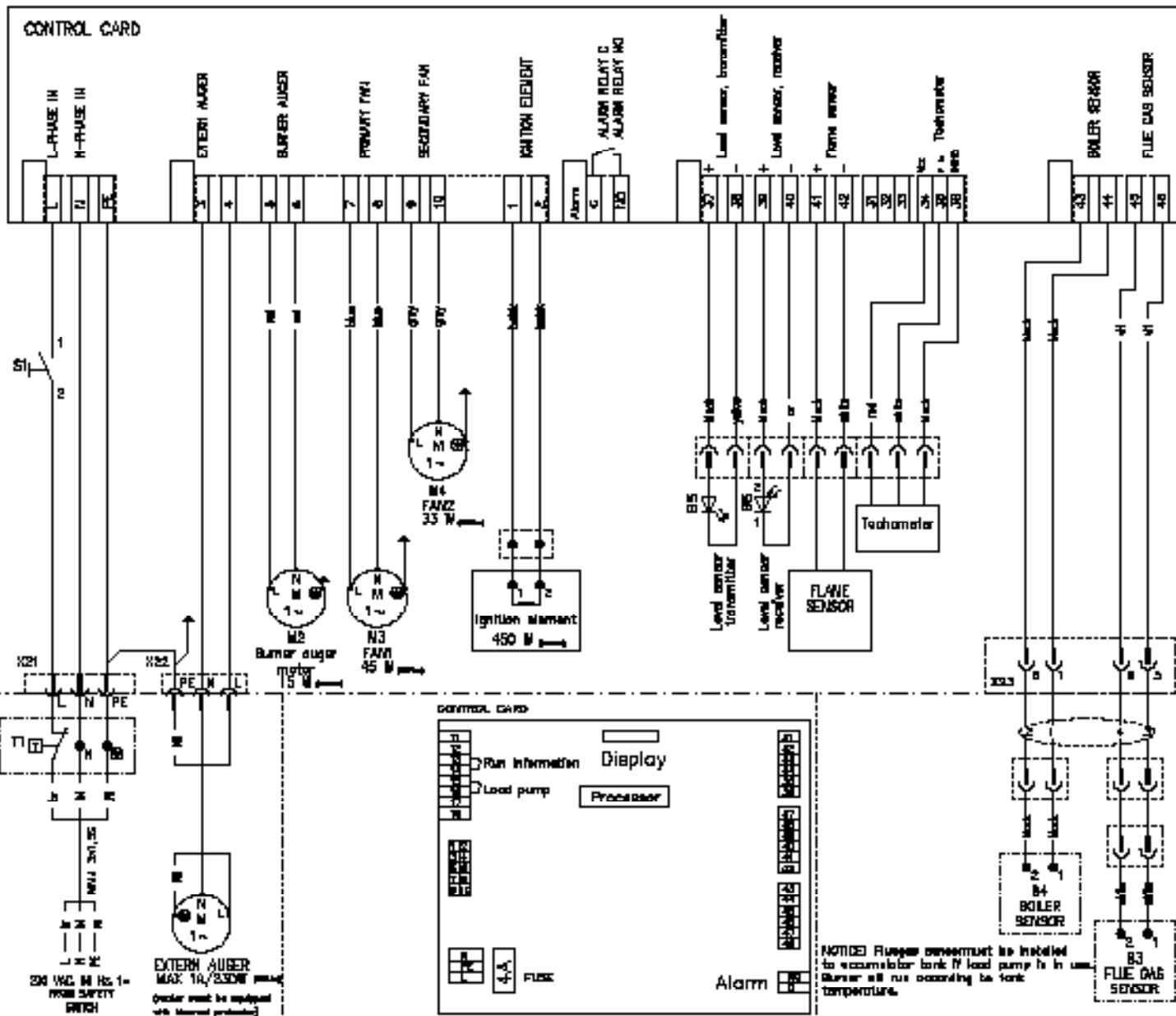
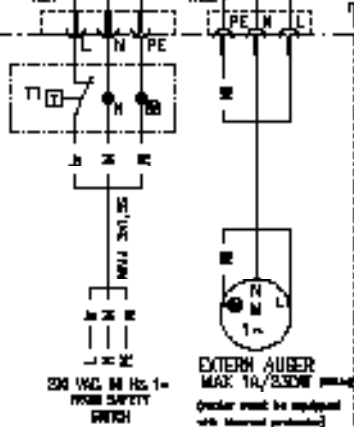





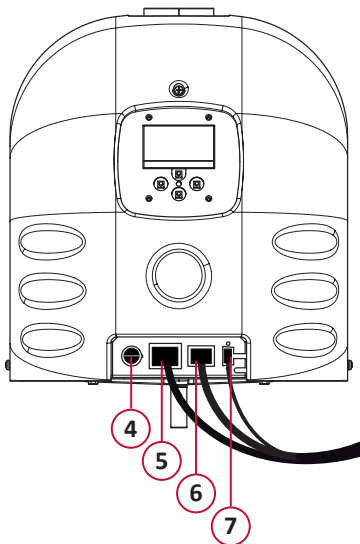
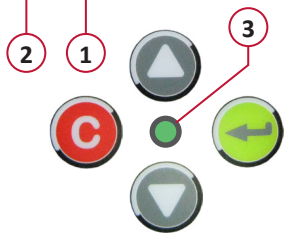
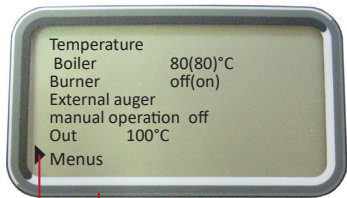

NOTICE: Fluegas sensor must be installed to accumulator tank if load pump is in use. Burner will run according to tank temperature.

CONTROL PANEL



1. Display
2. The display marker shows the selected setting.
3. Indication of operation and alarm with signal lamp
4. Burner power switch
5. External feeder auger
6. Burner power supply
7. Temperature sensor line

-  **Green:** Burner in operation
-  **Red:** Alarm (burner not in operation)
-  **Flashing light:** Warning (burner does not stop)
-   **Arrow buttons:** moving within menus/alteration of setting values.
-  **C button:** exit from menus/confirmation of warning/confirmation of setting value.
-  **Enter button:** choice of setting/moving to sub-menu.

BURNER OPERATION

Default settings

The factory settings are suitable in most cases. Only setting the desired boiler temperature is necessary, if this is too low or too high. In addition, the fan's output is affected by the mains voltage. If the mains voltage is low, the percentage output of the fan may need to be increased. (See Adjustment of Combustion.)

The main menu contains the most important settings for the burner function: start of burner, display of boiler and smoke gas temperatures and burner operating status. The sub-menus contain settings for regulating the burner and monitoring its operating status. A detailed description can be found in the MENUS section.

If no button is pressed during a certain period, a graphic image is shown where one can easily follow the burner's function.



The factory settings can be reset from the « Default settings ».

■ BURNER START, BURNER FUNCTION

■ Start and stop of the burner

Start the burner and the inner circulation pump with the operating switches. If the flow monitor is connected for control of the inner circulation pump, set the switch to the Off position. The main menu is shown on the display, and it displays the boiler water and smoke gas temperatures. The main menu also shows the burner's start/stop setting and status information. If no button is pressed during a 10 second period, the display shows a graphic image with information on the temperature and burner.

The first use is different from a normal start in that the burner is completely empty of pellets. The external feeder system is also empty of pellets.

On first use or if the store has become completely empty of pellets, do as follows:

1. Start the external auger from the main menu and wait until pellets come through to the burner's upper connection. The external auger will stop automatically after 15 minutes (setting can be modified).
2. Select "Burner On".

■ Cold start

The burner carries out a cold start with the help of the firing element when the boiler water temperature is more than 8 °C below the set value. In the menu's burner setting position, the text "Start phase 1K" is shown. The auger burner starts and the red signal lamp is illuminated. After a little while, the fan starts and the firing element is activated. The cold start consists of seven start phases 1K-7K. When the flame sensor detects a flame in the burner head, the burner goes directly to start phase 5K and the green signal lamp is lit. In start phase 7K, the burner stops for 10 minutes, for the combustion process in the burner head to stabilise. If a flame does not light after start phase 7K, the burner gives a cold start alarm. See the fault finding instructions.

Do not alter any settings while a cold start is in progress. After cleaning the burner head, make sure the burner does a cold start, since there are no embers in the burner head. The cold start can be ensured by raising the boiler water setting temperature sufficiently and then reducing it to the desired value when ignition has taken place.

■ Warm start

The burner carries out a warm start when the boiler water temperature is less than 8 °C below the setting value, for example after a short power cut. On warm start, the burner uses the embers in the burner head, saving energy. On normal use, when the burner goes from maintenance operation to normal operation, the burner carries out a warm start.

After a power cut, the burner starts automatically and carries out a warm start or a cold start, depending on the boiler water temperature.

■ Normal operation

After warm/cold start, the burner goes over to normal operation at high output. When the boiler water temperature has increased to 4 °C below the set value, the burner changes to low output. The factory settings give high and low output the same value. A green signal lamp shows that the burner is in operating mode. A flashing red signal lamp shows that the burner is running normally, but that there is a warning (for example, ash removal, time for cleaning or that the pellet store is empty). A red signal lamp shining continuously indicates that the burner has stopped because of an alarm. The reason for the alarm flashes on the display.

■ Burner stop

The burner can be switched off at any time, regardless of the combustion phase. Choose the operating mode "Burner Off" in the main menu and the burner will stop. Let the embers burn out before you clean the burner head. Turn off the power with the switch and release the power cable from the burner.

■ Using a burner with an accumulator

The burner comes with an optional accumulator sensor. This allows for controlling the burner according to the temperature of the accumulator (processor version v100615 or newer is required). Turn the Tank mode setting on from the Accessories menu, replace the flue gas sensor with the accumulator sensor and install it on the accumulator. After this, the burner is controlled through the accumulator sensor in the accumulator. The starting and stopping temperatures of the accumulator can be set in the Accessories menu. The Ember Maintenance setting will automatically switch to the No mode, thus the burner always performs a cold start.

In addition, the burner card enables the controlling of the load pump, for which a start-up hysteresis can be set with the setting Load Pump Diff. For example, the set temperature of the boiler water is 80 C and Load Pump Diff = 10 C. The load pump starts when the temperature of the boiler water is over 70 C and stops when the temperature is below 70 C.

■ ADJUSTMENT OF COMBUSTION

Settings that control the burner's combustion and functions can be found in the Power Settings menu.

■ Adjustment of combustion

In most cases, the factory settings give good and efficient combustion. The factory settings are suitable where the vacuum, measured in the boiler's combustion chamber, is around

8-15 Pa and 8 mm pellets are used. There is a bolt in the burner flange through which the underpressure can easily be measured. For the operation the burner cover must be detached.

In connection with commissioning, a professional installer should adjust the setting values with the help of a smoke gas analyser. The carbon monoxide (CO) value should be less than 200 ppm and the residual oxygen (O₂) 6,5-8 %.

If combustion is poor, smoke gas from the flue is black or the ash is grainy, the relationship between fuel and air can be adjusted in the Power Settings menu. The feed of pellets to the burner head can be adjusted with the settings High auger and Low auger. The necessary air amount for combustion can be adjusted with the settings High fan and Low fan. The minimum settings are not used.

■ Flue gas fan

If the draught is not sufficient, a flue gas fan can be installed in the flue pipe, if possible. If Ariterm's fan controller is used for controlling the flue gas fan, the operating data is received from terminal blocks 13 and 14 of the burner. This is connected to input T6 of the fan controller and- . When the burner runs in power mode, the fan runs according to the maximum setting. When the burner is in maintain mode, the fan runs according to the minimum setting. A cable and connectors are available as optional accessories for installing between the fan controller and the pellet burner.

■ Draught regulator

If the draught is too strong, a draught regulator can be installed in the flue.

■ Time for the external auger

When the pellet level falls below the level sensors in the burner's upper connection, the external auger starts. The external auger's operating time can be so long that the pellet level rises to a height level with the burner's upper connection. Pellets that rise up in the fall pipe can lead to blockages with associated alarm for lack of pellets.

MENU STRUCTURE

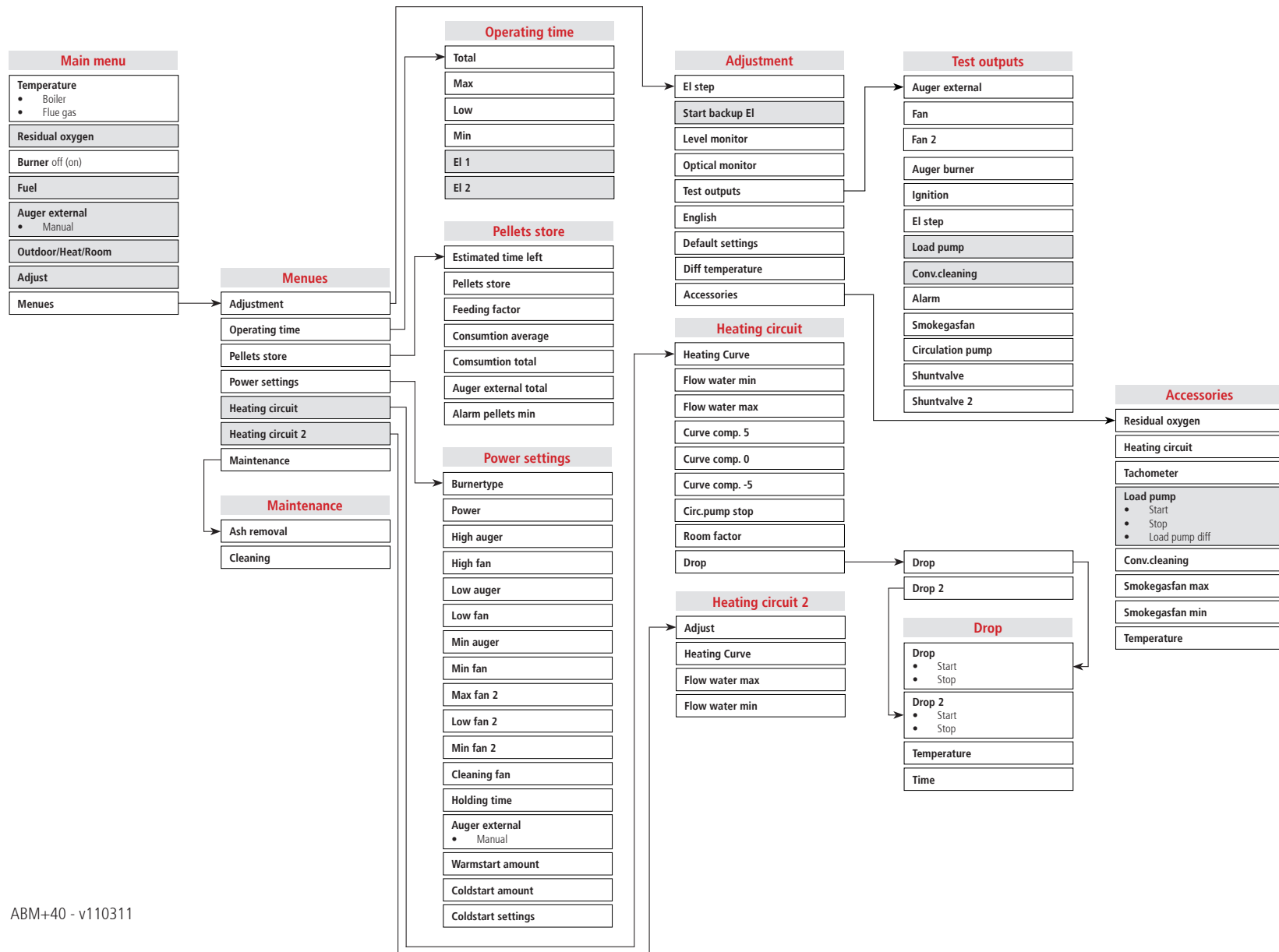

ABM+40 - v110311

■ MENU STRUCTURE

The following tables give an overview of the messages that may appear on the display of the control unit. They also indicate which parameters the user is allowed to change freely and which parameters he/she is allowed to change only if instructed to do so by an authorised installer. NOTE! Part of the menu options are displayed only when they are active.

■ Main menu

Menu	Setting	Description
Temperature Boiler xx (80) °C	5-95°C	Boiler temperature, set temperature in brackets.
Fluegas xx (250) °C	120-280°C	Flue gas temperature, alarm limit in brackets.
Residual oxygen x.x%	-	Displays the amount of residual oxygen while the burner is in Maintain mode (Accessory)
Burner Off (On) mode	On/Off	Burner start-up and stop. Burner operating mode below. Example: Output MAX
Auger external manual Off (On)	On/Off	External auger start-up (visible if the burner is in Off mode). The remaining operating time is shown in brackets. Can be stopped manually.
Fuel	Pellets Pellets + electricity Electricity	Heating method selection (visible if the electrical resistances are being used and the burner is in On mode - see "Burner Settings"). Only Biomatic+
Outdoor xx°C / Heat xx(xx) °C / Room xx(xx) °C	Room 0-30°C	Temperature display of heat regulation circuits (visible if activated from the Accessories menu). Only Biomatic+
Adjust	0-20 °C	Fine adjustment of heating circuit 1 (visible if activated from the Accessories menu and if the internal sensor is not connected) Only Biomatic+
Menus	-	Accessing submenus: Burner Adjustments, Operating Time, Pellet Store, Power, Heat Regulation, Service.

■ Menu Adjustment

Menu	Setting	Description
El step	0-3	Activation of electrical resistances, Only Biomatic+ 0 = not in use, 1= 3 kW 2=6 kW 3= 9 kW
Start backup El	10-40 °C	Activation temperature of electrical resistances.
Level monitor 99% (50%)	10-90%	Displays the pellet level between the level switches of the burner. The auger starts when the value falls below 50 %.
Optical monitor 99% (50%)	1-98%	Displays the flame strength. Limit value in brackets.
Test outputs	-	The burner functions (e.g., auger burner, blower, etc.) can be tested in the menu.
English	Suomi, Svenska, English, German, Italiano, French, Spanish, Russian	Menu language selection
Factory settings v110311	Yes / No	Restores the original factory settings.
Diff temperature No	No, 5-60°C	Burner operating lag time. The burner moves to Maintain mode at the target temperature and restarts when the temperature has decreased by the amount equal to the lag time. No = hysteresis 5 °C 5-60 °C = the burner runs only on Max. output.
Accessories	-	The menu can be used to take accessories into use.

■ Operating Time menu

Text on the display	Setting	Description
Total xx h	-	Burner total operating time in Power mode.
High xx h	-	Burner operating time at Max power.
Low xx h	-	Burner operating time at Mean power.
Min xx h	-	Burner operating time at Min power.
El 1	-	Operating time of the 6 kW electrical resistance.
El 2	-	Operating time of the 3 kW electrical resistance

■ MENU STRUCTURE

■ Pellet store menu pellet store and consumption monitoring

Text on the display	Setting	Description
Estimated time left xx days	Displays the amount of pellet fuel remaining in the store. A new value can be set in connection with a change in the pellet store.	Displays how many days the pellets in the store will last at the average consumption level in question.
Pellet store x.x t	0.0-25.0 t	Displays the amount of pellet fuel remaining in the store. A new value can be set when reloading the pellet store.
Feeding factor xx kg/h	0-76.0 kg/h	Feeding capacity of the storage auger.
Consumption average kg/day	-	Displays the average consumption during the last 8 days.
Consumption total x.x t	-	Displays the overall consumption of pellets.
Auger external total	-	Displays the operating time of the external auger
Alarm pellets min x.x t	0.0-3.0 t	A warning appears on the display when the calculated amount of pellet fuel left in the store is equal to the set minimum level.

The feeding rate of the storage auger can be determined, for example, by driving the storage auger for 10 minutes and by measuring the weight of the pellets which arrived at the vessel. Multiplying this by six gives how many kilograms the storage auger brings in an hour (kg/h). The feeding rate may vary according to pellet quality.

The Pellet Store setting is used to determine the amount of pellet fuel in the store. The automatic equipment calculates the consumption of pellets on the basis of the feeding rate and operating time of the external auger. In addition, it estimates whether the amount of pellet fuel will suffice for one day on the basis of average consumption.

The Alarm Pellets Min setting is used to determine the limit at which a message warning about the termination of pellets appears on the burner screen.

■ Power settings menu

Menu	Setting	Description
Burner type 40 kW	12/15/20/25/40 kW	Burner type selection. Select your own burner type. Note! Restore the factory values also for the settings related to heat regulation.
Power		
High auger 50 %	0-100%	Auger burner operating cycle at High power.
High fan 35 %	0-100%	Fan power at High power
Low auger 0 %	0-100%	Auger burner operating cycle at Low power
Low fan 35 %	0-100%	Fan power at Low power
Min auger 0 %	0-100%	Auger burner operating cycle at Min power.
Min fan 0 %	0-100%	Fan power at Min power
High fan2 65 %	0-100%	Fan2 power at High power
Low fan2 65 %	0-100%	Fan2 power at Low power
Min fan2 0 %	0-100%	Fan2 power at Min power
Cleaning fan 2/h	Off, 2/h, 1/h, 1/2h, 1/3h	In Power mode, the blower goes to 100% power and keeps the air vents clean.
Holding time 60 min	No, 0-120 min	Time between ember maintenance cycles. The auger burner carries out a 1-minute feeding cycle while the burner is in Maintain mode. No = The burner does not maintain the embers. In this case, the burner always performs a cold start when starting up. To be used, for example, with an accumulator.
Auger external 30 s	0-250 s	Operating time of the external auger when the level switches ask for pellets (see "Adjustment Example").
Manual 15 min	0-60 min	Operating time of the external auger during manual operation (the burner must be in Off mode, start-up from the main menu)
Warmstarts	0-	Number of hot starts
Coldstarts	0-	Number of cold starts
Coldstart settings	0-99	

■ Maintenance menu

Menu	Setting	Description
Alarm Ash removal x (100) h	0-250 h	Gives an alarm indicating that the ash box must be emptied (calculated from the operating time of the external auger). To be determined on the basis of experience.
Cleaning x (100) h	0-250 h	Gives an alarm indicating that the boiler and burner head must be cleaned. To be determined on the basis of experience.

MENU STRUCTURE

Accessories Menu

Menu	Setting	Description
Residual oxygen	On/Off	Fan power adjustment according to residual oxygen. The oxygen value can be seen in the main menu and in the graphic. Only Biomatic+
Heating circuit	On/Off	Heat regulation of two heating circuits possible. Menu Shunt control 2 is visible, when the sensor is connected. Only Biomatic+
Tachometer	On/Off	Not in use
Load pump	On/Off	Load pump function (tank sensor)
• Start	0 - 95 °C	Tank temperature, when burner start ignition
• Stop	0 - 95 °C	Tank temperature, when burner stops
• Load pump diff	0 - 50 °C	Load pump goes on, when boiler temp > set temp - Load pump diff
Conv. cleaning	On/Off	Commissioning of the automatic convection cleaning system and determination of operating times. See page 20. Only Biomatic+
Time On	3 min (0-10 min)	
Time Off	4 h (0-250 h)	
Smokegasfan Max	30 % (0-100 %)	Flue gas fan power in Power mode. Only Biomatic+
Smokegasfan Min	0 % (0-30 %)	Flue gas fan power in Maintain mode. Only Biomatic+

Load pump

If the boiler is connected to the accumulator, the load pump can be controlled with the burner control card according to the temperature of the boiler water, while the burner can be controlled according to the temperature of the accumulator. Connect the load pump to the control card of the burner according to the connection diagram. Install the flue gas sensor of the burner on the accumulator (middle or top). Set Load pump to On mode from the Accessories menu. The Ember Maintenance setting will automatically switch to the No mode so that the burner always performs a cold start by means of ignition resistance.

The burner starts by performing a cold start when the temperature of the accumulator is below the Start setting. After ignition, the temperature of the boiler water begins to rise. When the temperature of the boiler water is over the Boiler set temperature – Load Pump Diff, the load pump starts. For example, boiler setting = 80 °C and Load Pump Diff = 10 °C so that the load pump starts when the boiler water reaches 71 °C. After this, the temperature of the accumulator begins to rise, and when it reaches the Stop temperature, the burner stops. The load pump continues to run until the temperature of the boiler water drops below the limit (in the example, the load pump stops when the boiler water drops to 69 °C).

If the temperature of the boiler water rises to 95 °C, the burner stops instantly.

ALARMS AND TROUBLESHOOTING

In case an alarm becomes active, this is indicated by the burner on the display of the control panel with a red light and a text message. This facilitates troubleshooting, because the user can see the cause of the problem. The burner stops in connection with an alarm. The cause of the fault must be determined before switching the device on again. If an alarm is given often, this may be due to incorrect adjustments/settings. When the red light blinks, the burner display shows a warning message, for example, about the fact that it is time to empty the ash box. However, the burner functions normally. Acknowledge by pressing the C button. In order to check and service the burner, it is first necessary to cut the voltage supply and detach the burner connection wires before removing the burner from the boiler. After this, the burner cover can be detached and the inspection of the flame detection sensor or other component can be carried out.

Alarm message / Cause	Check	Procedure
<p>The burner has stopped and the display is dark.</p> <p>Voltage is no longer supplied to the burner.</p>	<ol style="list-style-type: none"> 1. Burner overheat protection. 2. Voltage supply fuse. 3. Glass tube fuses of the burner card and connection of the display panel. 	<ol style="list-style-type: none"> 1. Find out the cause of overheating and confirm receipt of the overheat protection. 2. Change the fuse. If the fuse continues to blow, contact an electrician. The connections must be checked. 3. The inspection may be carried out by an electrician. Take out the display panel and check the glass tube fuses of the controller card. Check the display panel connection.
<p>Alarm cold start</p> <p>The flame detection sensor has not detected any flames in connection with a cold start. The alarm is given 10 min after the end of the cold start.</p>	<ol style="list-style-type: none"> 1. Are there pellets in the burner head? 2. Operation and cleanliness of the flame detection sensor 3. Ignition resistance 	<ol style="list-style-type: none"> 1. If the burner head does not contain pellets but the upper connection of the burner does, try to reignite. Make sure that the burner head receives pellets. 2. The operation of the flame detection sensor can be checked by reflecting light on it. How the sensor reacts to it can be followed from the Burner Adjustments menu. The flame detection sensor may have become dirty due to weak draught. This prevents the sensor from recognising flames. See "Inspection and Maintenance". 3. Go to the Testing menu and turn the blower and the ignition resistance on. Make sure that the resistance heats up and ignites the pellets.

Alarm message / Cause	Check	Procedure
<p>Alarm optical monitor</p> <p>The flame detection sensor has not detected any flames for 10 minutes with the burner in Power mode. The level switches have requested more pellets, which means that pellets have arrived at the burner head..</p>	<ol style="list-style-type: none"> 1. Operation and cleanliness of the flame detection sensor. 2. Blower operation 	<ol style="list-style-type: none"> 1. See "Alarm cold start" (paragraph 2). 2. Go to the Testing menu and turn the blower on. Make sure that the blower works. <p>If the flame detection sensor becomes often sooty or overheated, this may be due to faulty adjustments or insufficient vacuum in the furnace. In these cases, contact the installer. The vacuum in the firebox can be increased by raising the exhaust extractor output in the menu Accessory. See page 14.</p>
<p>Alarm warmstart</p> <p>After a hot start, the flame detection sensor has not detected any flames for 10 minutes. The embers have all burnt and the burner does not use any ignition resistance when performing a hot start. After cleaning the burner head, the boiler water temperature may be within 8°C of the set temperature. In this case, the burner will try to perform a hot start. Since there are no embers, the alarm will be activated.</p>	<ol style="list-style-type: none"> 1. Operation and cleanliness of the flame detection sensor. 2. Ember maintenance time (Power menu) 	<ol style="list-style-type: none"> 1. Check the flame detection system as specified above. 2. Check the embers while being in Maintain mode. Excessive draught may burn the embers completely. In this case, reduce the draught and the time of the Ember Maintenance setting. <p>If the alarm has been given after cleaning the burner head, increase the set temperature of boiler water temporarily in order for the burner to be able to perform a cold start.</p>
<p>Alarm residual oxygen</p> <p>Residual oxygen has been under 4.5% for 2 min, which has caused poor combustion. The automatic power increase of the blower has not been enough.</p>	<ol style="list-style-type: none"> 1. Are the air vents of the burner head open? 2. Is the blower functioning well? Has the blower been correctly adjusted? 	<ol style="list-style-type: none"> 1. Clean the burner head and open the air vents. 2. Check the operation and power of the blower. Adjust fan output as necessary. <p>NOTE! If residual oxygen is set to Off mode, no alarm is given even if the residual oxygen value is displayed on the screen. Only Biomatic+</p>

ALARMS AND TROUBLESHOOTING

Alarm message / Cause	Check that	Procedure
<p>Alarm control level monitor</p> <p>The level switches have not detected pellets in the burner upper connection even if the external auger has run for four times its operating time.</p>	<ol style="list-style-type: none"> there are pellets in the store. pellets have not accumulated in the drop pipe. the level switches function well. the inclination of the drop pipe is not too steep (over 45°) or too gentle. the motor shaft rotates the auger and the external auger motor functions well. 	<ol style="list-style-type: none"> Add pellets and drive the external auger until the pellets arrive at the upper connection of the burner. Perform start-up. Adjust the operating time of the external auger according to the adjustment example Check the operation of the level switches from the Burner Adjustments menu. The value should decrease below the one in brackets. After this, the external auger should turn on. When the auger stops, the value should be 99%.
<p>Alarm blocked pellets</p> <p>The flame detection system has not detected any flames for 10 minutes and the level switch has not asked for more pellets. In other words, the burner head has run out of pellets and the flame has gone out.</p>	<ol style="list-style-type: none"> the level switch eyes are clean (dust). the level switch functions correctly. the burner wheel is fastened and the chain is in good state. pellets arrive at the combustion vessel. the flame detection sensor functions well. the feeding auger, blocking feeder and auger burner rotate and are not blocked due, for example, to a foreign object. 	<p>If there is no fuel in the upper connection of the burner, check the cable connections of the level switches. If this does not help, wipe the level switches clean. If the external feed of the burner does not start in spite of this or the level switches must be cleaned all the time, they may be defective and the installer should have a look at them.</p> <p>A possible foreign object in the pellet fuel must be removed if it gets stuck in the blocking feeder or in one of the feeding augers. Remove the upper connection and take out the possible foreign object from the feeding auger or blocking feeder.</p>

Alarm message / Cause	Check that	Procedure
<p>Alarm boilersensor</p> <p>The boiler water temperature sensor is detached</p>	the boiler sensor is in place and the wires are intact.	If the boiler sensor wire is not connected or is broken, the sensor shows the reading 0°C and the alarm is activated.
<p>Alarm max flue gas</p> <p>The flue gas temperature has exceeded the alarm limit.</p>	<ol style="list-style-type: none"> the bypass damper of the boiler is in place. the flue gas sensor is in the flue gas channel. 	<ol style="list-style-type: none"> Put the bypass damper in place Place the flue gas sensor in the flue gas channel.
<p>Alarm max thermostat</p> <p>The boiler water temperature sensor shows more than 99 °C.</p>	<ol style="list-style-type: none"> the circulation pump is on the set boiler water temperature 	<ol style="list-style-type: none"> Switch the circulation pump on. The maximum set temperature for boiler water is 95°C. However, the temperature may rise above this limit due to residual heat. In this case, decrease the setting. <p>The cause of overheating must be found out before restarting.</p>
<p>Alarm Fan tach</p> <p>The fan is not rotating</p>	1. The fan is rotating	The tachometer monitors the operation of the blower. If it detects that the blower is not rotating, an alarm is given and the burner stops. However, if the blower is functioning, the fault may be in the tachometer. The tachometer can be switched off from the Accessories menu.
<p>Alarm cleaning</p>	The burner gives a warning when it is time to clean the burner head. The time is calculated from the auger's operating time. The interval can be set in the Service menu. The setting 0 means that the function is off.	
<p>Alarm ash removal</p>	The burner gives a warning when it is time to empty the ash box. The time is calculated from the auger's operating time. The interval can be set in the Service menu. The setting 0 means that the function is off.	

■ SERVICE AND MAINTENANCE

Regardless of the type of solid fuel used, more care is required compared to burning oil. The service requirements can be considerable. We recommend that the burner, boiler and its convection parts are checked and cleaned after a week's operation. In this way, the service requirement can be determined. These service actions should be repeated regularly.

In the burner's Maintenance menu, you can set the interval for Ash Removal and Cleaning as a number of hours. When the set time has expired, a message is shown on the display and a red signal lamp flashes. The burner does not stop. The burner calculates the time based on the auger burner's operation, which means that the service requirement is determined from the output requirement. Check the pellet quality on new deliveries and change of supplier.

■ Burner

How to carry out boiler cleaning:

1. Stop the burner an hour before servicing the boiler.
2. Disconnect the boiler's power supply and pull the burner out of the boiler. Where necessary, remove hardened ash from the burner head. Use a tool such as a screwdriver. Check that the primary air ring's air holes are open and that hardened ash has not collected beneath the auger burner. In connection with a new fuel delivery, the burner head should be checked, so that sinter (ash that has collected in the burner head, and fused together and stony gravel-like particles) is detected in time. Such particles must be removed from the burner head regularly, and at short intervals, so that the primary air ring does not become overheated and thereby damaged.
3. Check that there is no ash in the flame sensor pipe.
4. Fit the burner back into place. Check that the seal between the burner and the flange is not damaged.

Service actions that should be carried out less frequently, every 1-2 years:

1. Unfasten the burner bowl's inner part and clean it internally of ash and other solid substances. At the same time, clean the primary air ring. The burner bowl's inner part is fixed to the outer part with four screws (screwdriver). By loosening these, you can remove the inner part and at the same time clean the primary air ring. When the primary air ring is replaced, ensure that the firing tube's mouthpiece is visible in the burner bowl's hole.
2. Check wear on the chain wheel and the wheel's fixing (Allen key).
3. Check the wear on the chain and its tension. The chain can be tensioned by moving the burner motor, but do not tension too much. Grease the chain with thin oil.

■ CLEANING THE BURNER

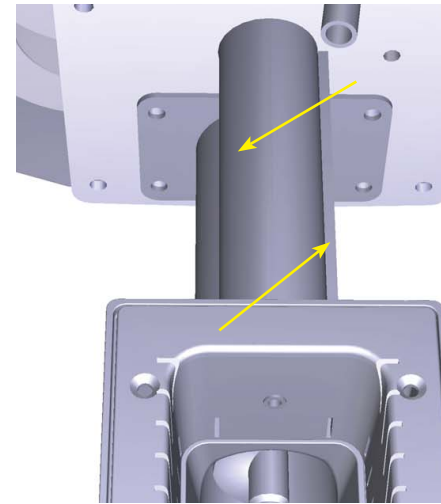

Clean the burner bowl of ash and any sintering. The primary air ring's air holes and the firing element's holes should be open.

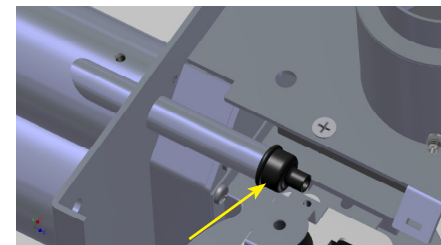

Hold the flame sensor's rubber cap and pull the flame sensor carefully from its pipe.

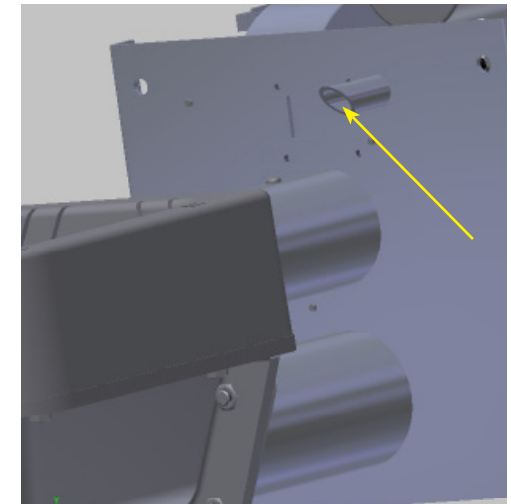

Clean the flame sensor's metal pipe so the ash that has collected in the pipe does not prevent the flame sensor from working.



Clean the flame sensor of contaminants.

Note!

If the flame sensor's protective glass breaks or becomes loose, the flame sensor will no longer work and it must be replaced with a new one.

SERVICE AND MAINTENANCE

Sintering is often due to contaminants in the fuel and a complaint should immediately be made to the fuel supplier.

Boiler

Carry out the following actions:

1. Empty the ash box.
2. Sweep out the boiler's convection parts when the smoke gas temperature has climbed 30 °C above the value at the previous boiler cleaning. Ash that has collected in the convection part impairs boiler efficiency.

Procedure in an emergency

If the heating equipment begins to burn, stop the equipment's operation with the separate safety switch (burner switch). Close the combustion air to the boiler room. Extinguish the fire by smothering it or with a fire extinguisher. Alert the fire brigade if necessary.

Warranty

Ariterm Energy Oy provides a two-year warranty on the burner, starting from the installation date. The warranty covers any defects in work and/or materials on the burner. The manufacturer is not liable under the warranty if the defect is caused by an installation fault, faulty use, freezing, overheating or overpressure. If repair has been started without authorisation from the manufacturer the warranty ceases to apply. The manufacturer is not responsible for indirect damage or costs that are caused by the burner.

Ariterm Energy Oy retains the right to decide in which manner the warranty repair should be carried out. Ariterm Energy Oy is not responsible for damage outside the warranty period, but separate agreements can be made in relation to such damage.

Decommissioning

A scrapped burner is suitable for recycling, while the plastic casing is waste that can be disposed of at a waste station.

SPARE PARTS AND ACCESSORIES

Spare parts Ariterm BeQuem

Burner parts are on page 3.

13245 Boiler sensor



13249 Flue gas sensor



Accessories Ariterm BeQuem

13245 Accumulator tank sensor



Running information connection cable for flue gas fan control

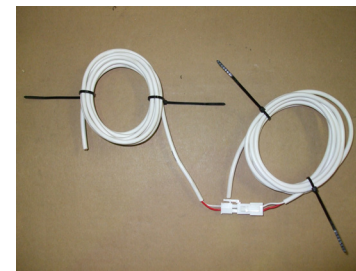

WOOD PELLETS AS FUEL

Wood pellets are renewable bioenergy and provide fuel in a compact and uniform form, which is easy to handle. The moisture content is less than 10%, which means that the pellets do not freeze or become mouldy. No chemical substances are used in the manufacturing process. Instead, the binding agent is the tree's own lignin.

The pellet diameter is 6 to 12 mm and the length is 10 to 30 mm. Due to their small size, the pellets move freely in the feeding augers.

NOTE!

The burner has been adjusted for 8 mm pellets at the factory. If pellets of other sizes are used, the burner must be readjusted..

Most of the disturbances that occur as a result of bad fuel quality are caused by incorrect handling and intermediate storage before the product is delivered to the customer. Large contents of fine materials may be due to insufficient sifting. Ash sintering is often caused by silicate impurities (sand). These materials cannot be detected before burning. NOTE! If the ash is sintered, all sintered material must be continuously removed from the burner head.

Fuel recommendation	
Raw material	Chemically untreated, barkless wood
Diameter	8 mm
Length	15-32 mm
Volume weight	over 600 kg/m ³
Moisture content	less than 10%
Ash content	less than 0.7 weight %
Fine material content	max 4 weight %
Ash melting temperature	> 1,100 °C
Energy content	>4.75 kWh/kg

DECLARATION OF CONFORMITY

■ INSTALLATION REPORT

After installation, the burner must be adjusted using a flue gas analyser.

Flue gas temperature - Max	CO	O ₂	CO ₂
Combustion efficiency	Draught mm	Blower %	Auger %
Flue gas temperature - Mean	CO	O ₂	CO ₂
Combustion efficiency	Draught mm	Blower %	Auger %
Flue gas temperature - Min	CO	O ₂	CO ₂
Combustion efficiency	Draught mm	Blower %	Auger %

Dealer / Installer
Installer
Date

ARITERM ENERGY OY | Uuraistentie 1
43100 Saarjärvi | www.ariterm.fi | 0771-442850

